

Current part is item (3) on diagram. Available at [www.oshkoshequipment.com](http://www.oshkoshequipment.com)

(1) (a) FIG. NO.	(2) (b) ITEM NO.	(3) SMR CODE	(4) NATIONAL STOCK NUMBER	(5) (6) PART NUMBER	(6) DESCRIPTION	(7) U/M	(8) INC IN UNIT
USABLE ON CODE							
0106 - ENGINE LUBRICATION SYSTEM (CONT'D)							
8	21	PAOOO	2940-00-363-7770	7397537	19207 FILTER,FLUID,PRESSURE:HEAVY DUTY,STRAP MOUNTED AA	EA	1
8	22	PAOZZ	4730-00-012-7951	127951	24617 PLUG,PIPE:OIL FILTER BODY AA	EA	1
8	23	XA	5306-00-298-7836	7529094	19207 BODY:OIL FILTER AA	EA	1
8	24	PAOZZ	2940-00-141-9026	MS35345-1	96906 FILTER ELEMENT,FLUID PRESSURE: OIL FILTER BODY AA	EA	1
8	25	PAOZZ	5330-00-599-1285	A1235	24617 WASHER,NONMETALLIC: ELEMENT AA	EA	1
8	26	PAOZZ	5360-00-253-7257	A308282	24617 SPRING,HELICAL,COMPRESSION: COVER SCREW AA	EA	1
8	27	XBOZZ		7529093	19207 COVER,OIL FILTER:BODY AA	EA	1
8	28	PAOZZ	5310-00-262-3000	713057	12603 WASHER,FLAT:COVER SCREW AA	EA	1
8	29	PAOZZ	5306-00-298-7836	5308280	19207 BOLT,SHOULDER:COVER SCREW AA	EA	1
9	1	PAOZZ	4730-00-196-1486	192054	24617 NIPPLE,PIPE:VENTILATION LINE AT HEAT ADAPTER AA	EA	1
9	2	PAOZZ	4730-00-618-6789	192087	21450 COUPLING,PIPE:HEAT CONTROL ADAPTER NIPPLE AA	EA	1
9	3	PAOZZ	4730-00-289-1254	137407	24617 ADAPTER,STRAIGHT,PIPE TO TUBE: BRAKE VALVE TO AIR CLEANER VENT LINE AA	EA	1
9	4	XBOZZ		7368701	19207 LINE ASSEMBLY:VENTILATION VALVE AA	EA	1
9	5	XBOZZ		7368699	19207 LINE ASSEMBLY:DISTRIBUTOR AIR CLEANER AA	EA	1
9	6	PAOZZ	4730-00-289-1254	137407	24617 ADAPTER,STRAIGHT:PIPE TO TUBE AA	EA	1
9	7	PAOZZ	4730-00-737-3368	7373368	19207 TEE,PIPE TO TUBE:FUEL LINES AA	EA	1
9	8	PAOZZ	4730-00-288-9953	187343	24617 ADAPTER,STRAIGHT,PIPE TO TUBE: CRANKCASE TEE TO DISTRIBUTOR VENTILATION LINE AA	EA	1
9	9	PAOZZ	4820-00-752-1945	7521945	19207 VALVE:CRANKCASE VENTILATION AA	EA	1
9	10	PAOZZ	4730-00-277-5553	MS51952-2	96906 ELBOW,PIPE:VENTILATION VALVE AA	EA	1
9	11	PAOZZ	2805-00-695-7172	7373209	19207 LINE,CRANKCASE:DISTRIBUTOR AA	EA	1
9	12	PAOZZ	4730-00-640-1051	137422	24617 ELBOW:DISTRIBUTOR END AA	EA	1
9	13	PAOZZ	4730-00-277-8768	137406	24617 ADAPTER,STRAIGHT,PIPE TO TUBE: DISTRIBUTOR END AA	EA	1
10	1	PAOZZ	6680-00-887-1334	10912158	19207 GAGE,OIL,LIQUID LEVEL:OIL AB,AC	EA	1
10	2	PAOZZ	5330-00-737-6332	7376332	19207 PACKING PREFORMED:OIL LEVEL ROD AB,AC	EA	1
10	3	XA		10912158-1	19207 ROD,LIQUID LEVEL GAGE:OIL AB,AC	EA	1

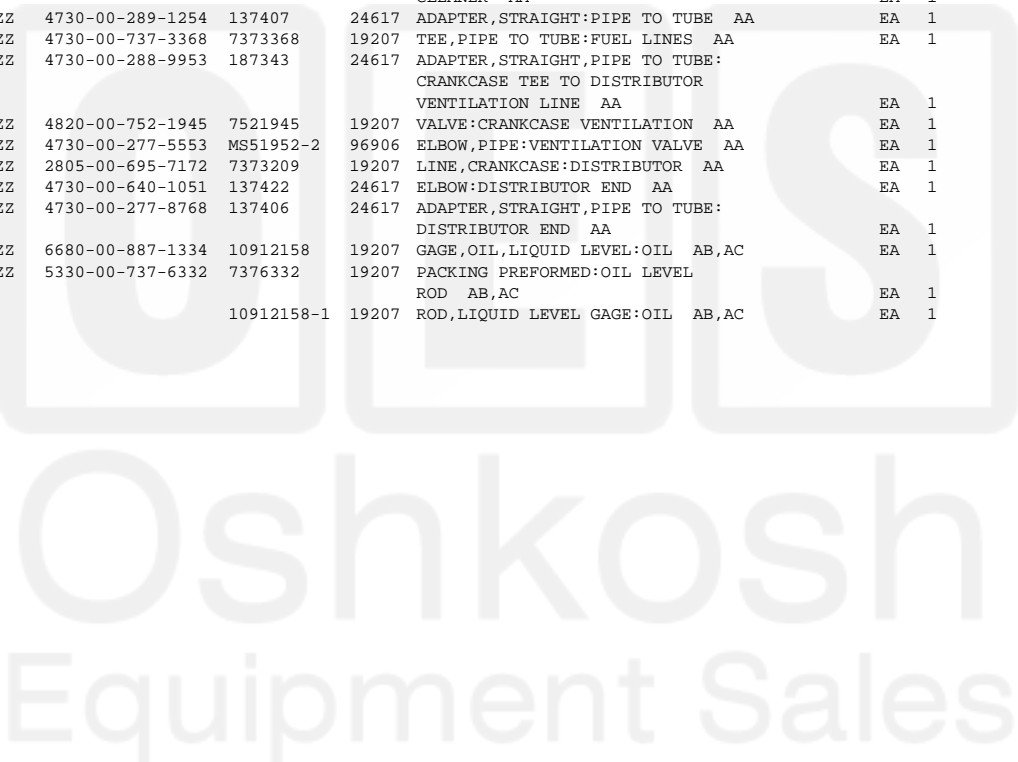

Current part is item (3) on diagram. Available at [www.oshkoshequipment.com](http://www.oshkoshequipment.com)

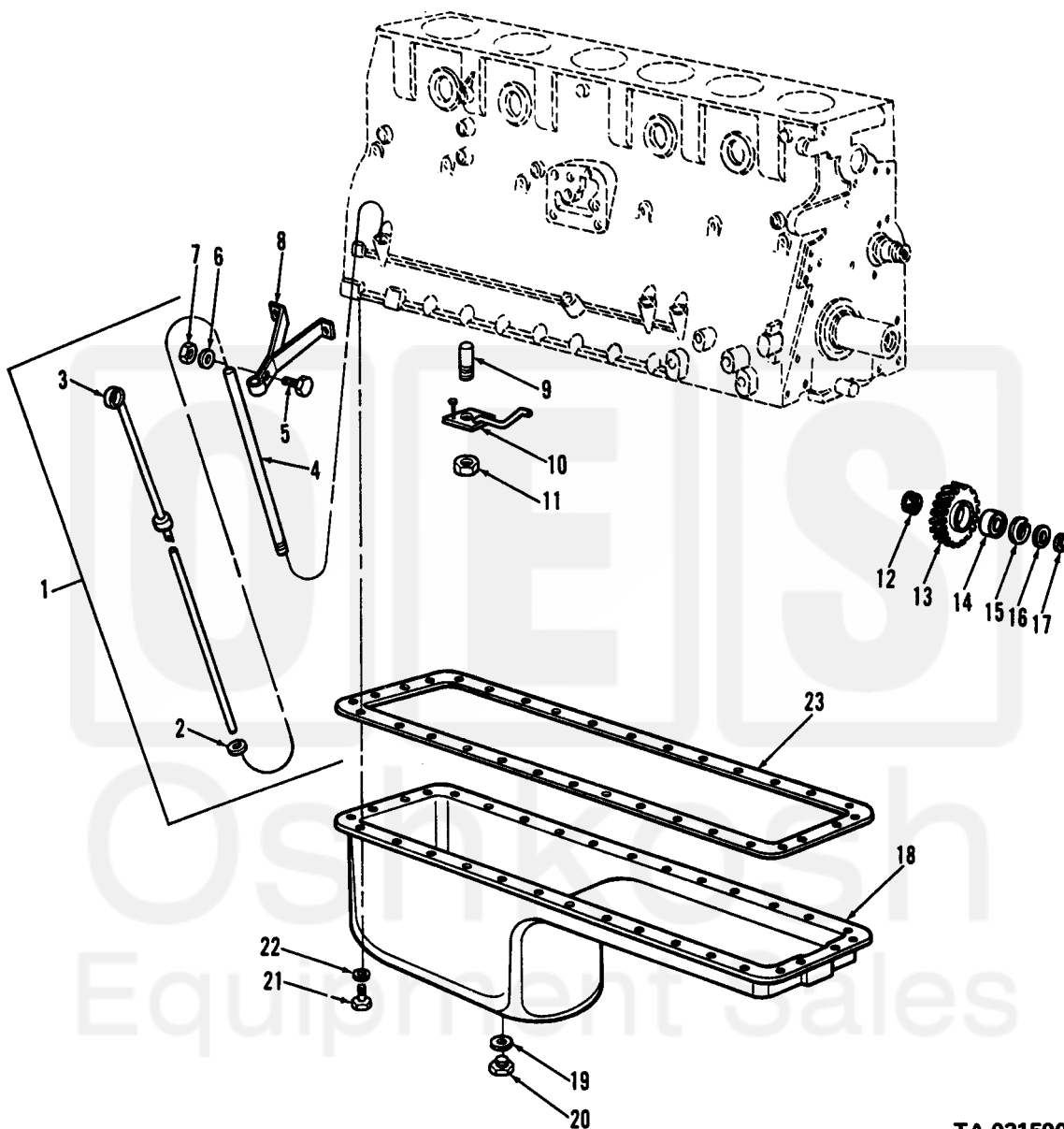

TA 031500

Figure 10. Oil pan, oil pump idler and associated parts.